



- **Optimal two stage charging**
- **State of charge / service LEDs**
- **Low standby battery drain**
- **Customizable charge algorithm**
- **Optional control / status signals**
- **Optional temp compensation**
- **Vibration resistant**
- **Reverse polarity protected**
- **Over temperature protected**
- **Over current / voltage protected**
- **Waterproof / hermetically sealed**
- **UL/CSA 1236 certified**
- **Two year warranty**

Description

The CT150-1 is a rugged, waterproof and sophisticated two stage lead-acid battery charger. With a wide operating temperature range (-20C to 50C) and UL/CSA1236 certification, this product is especially suited for high end industrial applications. The CT150-1 is factory programmable to accommodate several charging algorithms and an LED display to indicate

status. The CT150-1 precisely controls charging voltage and current to insure a complete recharge every time. The charger may be left connected indefinitely to the battery, maintaining full charge at all times. The CT150-1 can be purchased with either ring terminals only or an interchangeable ring terminal / alligator clip termination.

Charging specifications

PARAMETER	DESCRIPTION / CONDITIONS	MIN	NOM	MAX	UNITS
V_{FL}	Float voltage, $I_{OUT} < 1.0 A$, 25 C	13.4	13.6	13.7	VDC
I_{FS}	Charge current, $V_{BATTERY} = 12V$	1.5		2.0	Amps
I_{SBY}	Standby current, AC off			0.5	ma

Charging algorithm: Supplies constant current to battery until V_{FL} is reached. Transition to float mode follows and regulates battery voltage at V_{FL} .

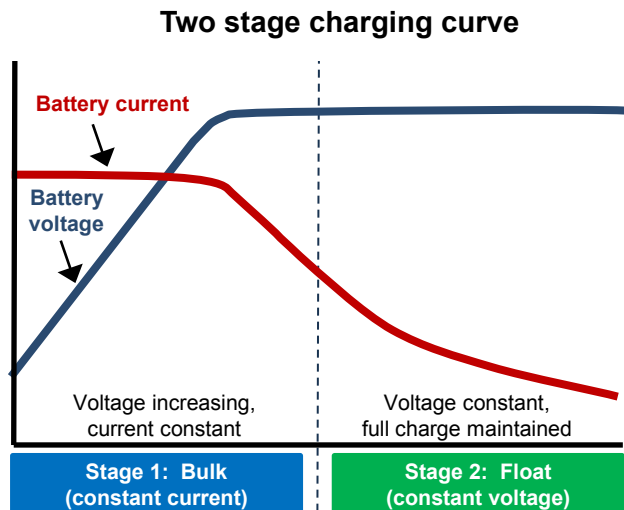

CT150-1 Datasheet

Input specifications

PARAMETER	DESCRIPTION / CONDITIONS	MIN	NOM	MAX	UNITS
AC voltage	47 - 63Hz	90	110	132	VAC
Input current	90VAC, 15VDC output		0.75		Amps

Environmental specifications

PARAMETER	DESCRIPTION / CONDITIONS
Storage temperature	-40°C - 80°C
Operating temperature	-20°C - 50°C
Relative humidity	0 - 95% relative humidity (non-condensing)
Input to output / chassis voltage isolation	2KV (leakage current less than 1mA)
Output to chassis voltage isolation	50V (can be increased / consult factory)

LED indicators

PARAMETER	DESCRIPTION	RED	GREEN
Battery connected	Indicates proper battery connection		On
Service indicator	Indicates a charger failure	On	

Outline and mounting

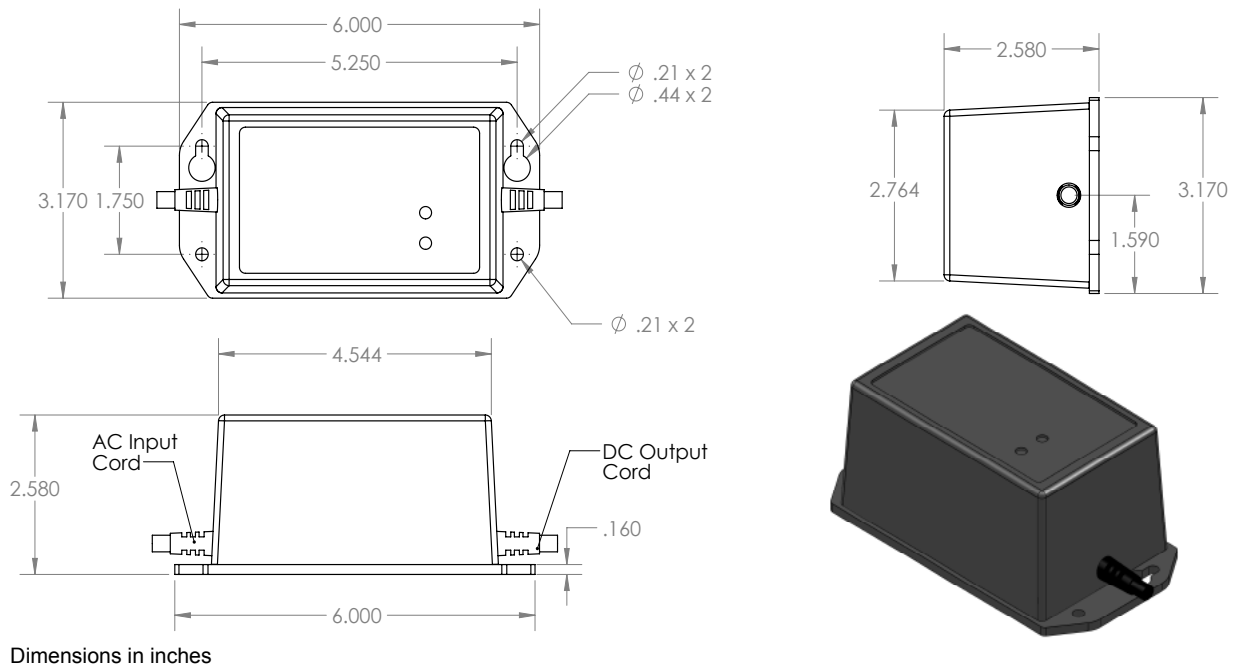

NOTE: Chargetek products are not authorized for use as components in life support systems, hazardous environments, nuclear control systems or other similar applications without the express written consent of the President of Chargetek, Inc. The appearance of products, including safety agency certifications pictured on labels, may change depending on the date manufactured. Specifications are subject to change without notice.